



CONTROLS

Closed loop control overview

Most tension controls work in closed loop configuration. In this case the **CONTROLLER** is indispensable. This element is the heart of the system. The control is continuously comparing the web tension information coming from the **SENSOR** with the tension reference we give to the controller. As soon as the controller detects a difference between the two values a correction is applied to the power element through the driver.

WARNER / WICHITA CONTROL LINE OVERVIEW

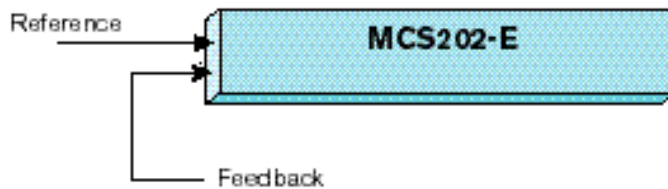
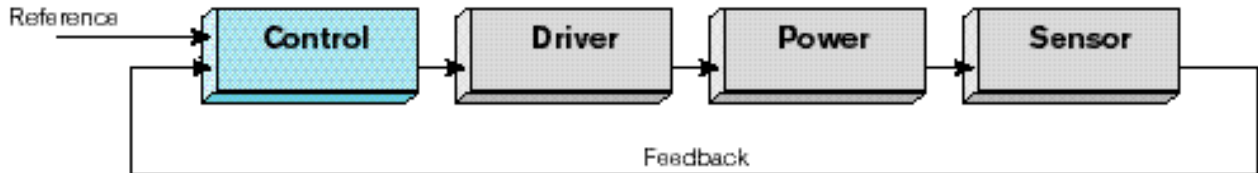

Low cost analogue control including driver in 3 versions:

- MCS202-E1 standard version.
- MCS2000-E54 IP54 protected.
- MCS202-EC1 Open frame standard version.

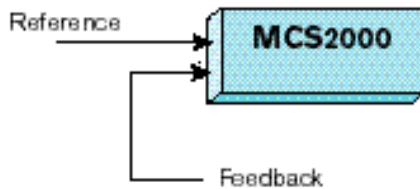

Digital control in 3 versions:

- MCS2000-ECA OEM version.
- MCS2000-CTDA user version for dancer application.
- MCS2000-CTLC user version for load cell application.

Typical applications

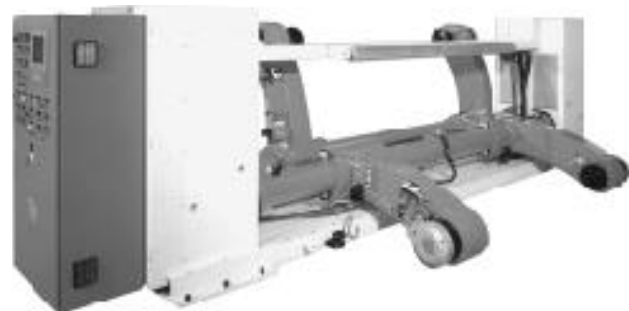
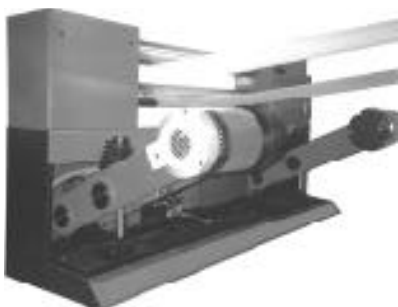



MCS202-E line

CONTROLS

The **MCS202-E** is an analogue control. It is dedicated to electromagnetic brakes and accepts only dancer as feedback. The control is not provided with internal logic function for splice. It suits the simple application and is very easy to start-up. All connections are made by connector avoiding the wiring error risk. Warner can supply the sensor and other accessory for easy mounting.

ANALOGUE CONTROL MCS202-E

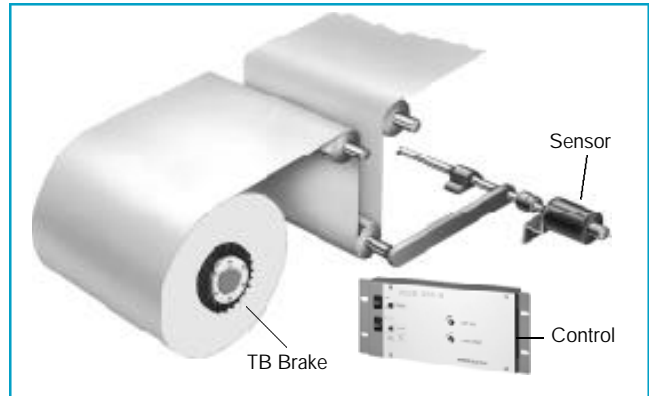
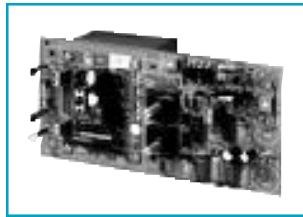

- ☐ MCS202-E1 Standard execution.
- ☐ MCS202-E54 Standard IP54 protected.
- ☐ MCS202-EC1 Open frame execution.

Technical Characteristics – valid for 3 executions

	Range - Values	Comments
Power supply	110-220 VAC selectable	Open front face to acced
Output current capability	Max 2, 5 Amps, shortcircuit protected	Able to power 2 TB in parrallel
User settings	Loop gain Offset torque	Front face potentiometer Front face potentiometer
Output voltage	0-24 VDC	Compatible all elec. Warner brakes
Housing	Metal rugged housing	Only MCS202-E1 and -E54
Loop gain	2 adjustable range selection	Can be change during operation
Accessories	MCS-KIT1, 2, 3, 5 and 6	See details on page 48
Sensor compatible	Dancer arm with MCS605-E	See details on pages 45 and 48

Technical information

MCS202 control is based on classical and fixed PID terms. The loop gain can be set on front face potentiometer. Due to the fixed PID terms, its use is limited in terms of roll diameter ratio. One input is provided to change the loop gain and has to be used when diameter ratio exceeds 8 to 10. To ensure proper operation it is important to wire the function "Drift Stop". This function releases the Integral term as soon as the machine runs.

Dimensions

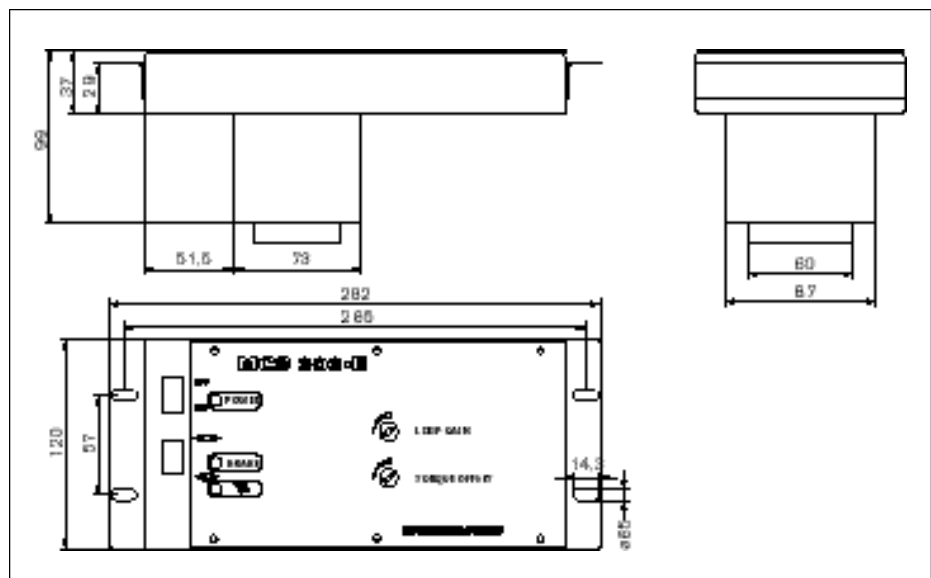



CONTROLS

MCS2000 line configuration

MCS2000 is a product line developed around the controller **MCS2000-ECA**.
MCS2000-ECA is the heart of the complete configuration grouping Driver, Power supply, Programming tool, Display, Interface sensor...
 The configuration is represented in the diagram below.

MCS2000 LINE CONFIGURATION



MCS2000-ECA	Digital programmable controller - dual channel output.	36
MCS2000-PS	24 VDC power supply - 100-260 VAC auto-ranging input.	47
MCS2000-DRV	Dual channel brake amplifier with individual "anti-residual" adjustment.	30
MCS2000-DRVH	Dual channel brake amplifier with high output current capability.	30
MCS2000-PSDRV	Dual amplifier MCS2000-DRV and power supply MCS2000-PS in common housing.	30
MCS2000- PRG	Portable programming tool with 2 lines 16 character display.	47
MCS2000- DP	Panel mounted programming keyboard and display.	47
MCS2000-CRD	Plugable memory card with 2 full programme capacity.	47
MCS2000-IS	Ultrasonic and dual load cell interface.	47
MCS2000-WIN	Window software to interface the control to the PC (3 disks).	47
MCS2000-PLC	Codes list for PLC (terminal mode) - RS232 controller communication.	47

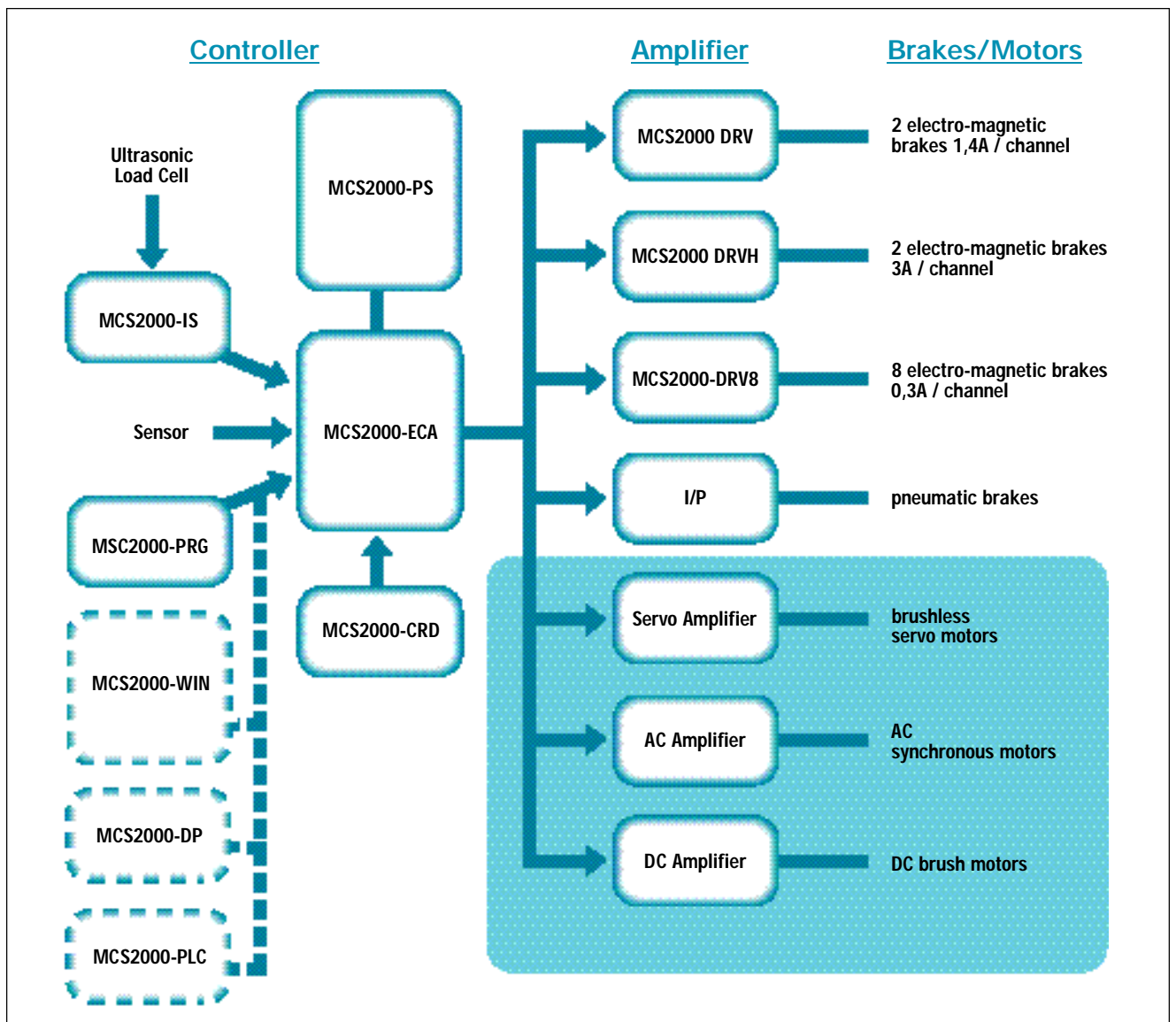





CONTROLS

MCS2000 line - characteristics

Based on the **MCS2000-ECA** controller Warner has developed two additional versions as a "User Version". These two versions were obtained by grouping some existing functions in the modular configuration. These two versions make the installation and wiring easier. The programming tool – separate on the ECA version – is fitted as standard. Finally, three digital control units are available in the **WARNER / WICHITA** range:

MODELS	MAIN CHARACTERISTICS	UTILISATION
<p>MCS2000-ECA</p> 	<p>Open + Closed loop control PID compensation RS232 Memory card 24V power supply See details on page 36</p>	<p>Multipurpose OEM</p>
<p>MCS2000-CTDA</p> 	<p>MCS2000-ECA + PS + DP in same housing. 110-240VAC power supply See details on page 37</p>	<p>Dedicated dancer</p>
<p>MCS2000-CTLC</p> 	<p>MCS2000-ECA + PS + DP + IS in same housing. 110-240VAC power supply See details on page 37</p>	<p>Dedicated load cell</p>
<p>Use the reference below to order with various software :</p> <p>MCS2000-ECA</p> <p>MCS2000-CTDA-10</p> <p>MCS2000-CTDA-11</p> <p>MCS2000-CTLC-10</p> <p>MCS2000-CTLC-11</p>	<p>Standard software with RS232</p> <p>Standard software with RS232</p> <p>Taper position function Limited RS232</p> <p>Standard software with RS232</p> <p>Taper tension function Limited RS232</p>	<p>Multipurpose OEM</p> <p>Dedicated dancer</p> <p>Dedicated dancer</p> <p>Dedicated load cell</p> <p>Dedicated load cell</p>



MCS2000 line - characteristics

CONTROLS

The block diagram below shows all important features installed in the MCS2000 control line. It is very important to understand all the possible configurations that the control can provide.

MCS2000 Block diagram

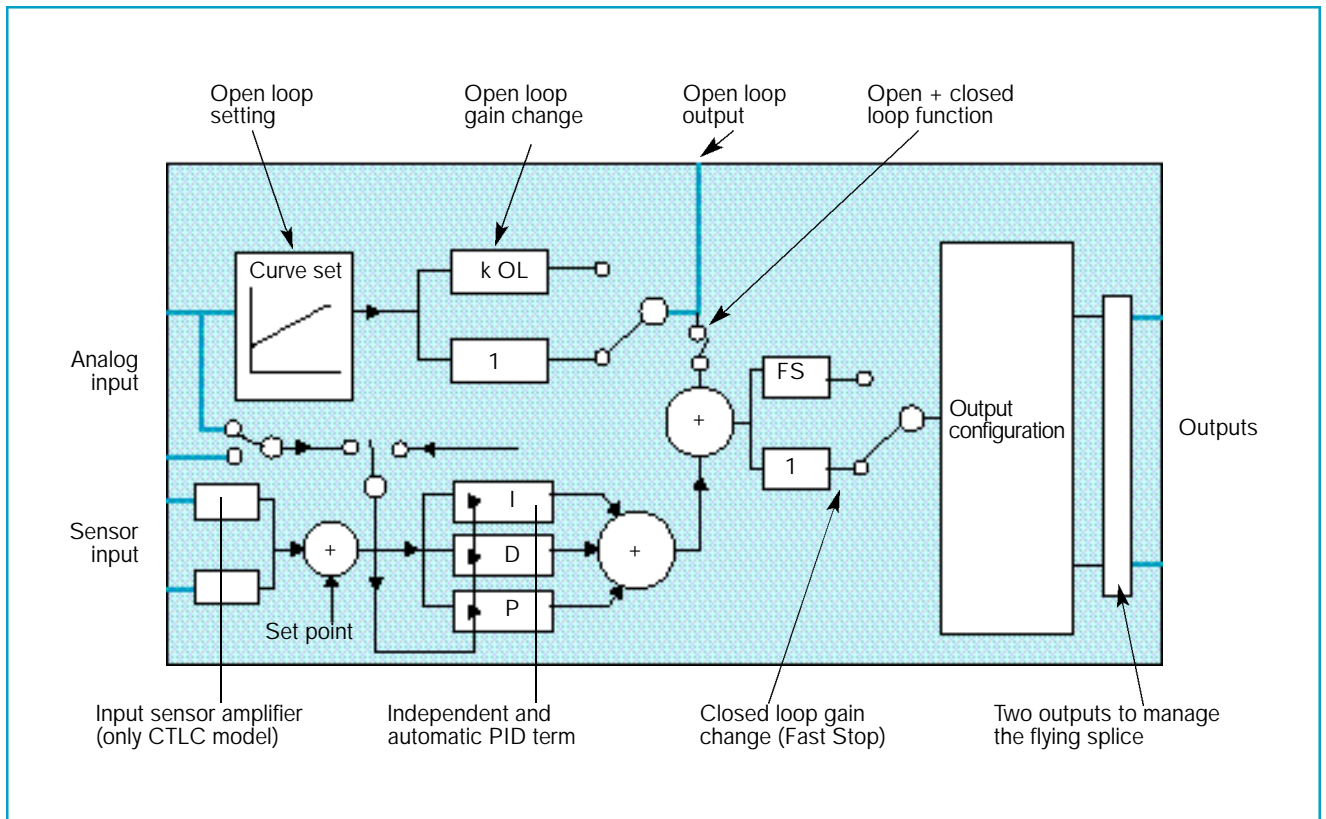

MCS2000 Features

Features / compatibility	ECA	CTDA-10	CTLC-10	CTDA-11	CTLC-11
Power supply 110 / 240 VAC		✓	✓	✓	✓
Power supply 24 VDC	✓				
Dancer use, one sensor input	✓	✓		✓	
Load cell use, 2 sensors input			✓		✓
RS232 communication	✓	✓	✓	✓	✓
Window software programming system	✓	✓	✓		
Taper function				✓	✓
Splicing capability	✓	✓	✓	✓	✓
Sensor auto-scaling	✓	✓	✓	✓	✓
Memory card support	✓	✓	✓	✓	✓
PID, individual term setting/online correction	✓	✓	✓	✓	✓
Options, accessories, (see details on pages 42 and 47)	PRG				
	DP				
	PS				
	CRD	CRD	CRD	CRD	CRD



CONTROLS

MCS2000-ECA

MCS2000-ECA is a digital controller that can be used in both open or closed loop. Operation in open and closed loop is also possible. It is mainly destined for OEM application. The programming tool is detachable. Sensor, sensor mounting kit, display are available as options. The unit has to be powered with 24 VDC.



Specifications

Input power supply	24 VDC ± 5%, 0,2 Amp
Analogue inputs	
Two analogue inputs	0-10 VDC
Sensor input	Min 4 VDC delta in ± VDC
Analogue outputs	
Two controlled channels	± 10 VDC, 0-20 mA
Open loop signal	0-10 VDC
Digital inputs	
Set point change +	active low
Set point change -	active low
Gain multiplier	active low
Open + closed loop activation	active low
Output limitation	active low
ABC binary combination	active low
ABC inputs synchronisation	active low
Sensor polarity change	active low
Stop integral term	active low

Features

- Fully digital, scrolling menu program.
- Multipurpose application.
- RS232 communication.
- Window programming software.
- Two output channels.
- Automatic sensor scaling.
- Programmable output configuration.
- Output sensor information.
- External set point change.
- Automatic or imposed PID correction.
- All features requested for tension control.
- Pluggable memory card.
- Sensor rescaling without tool.

Digital output	
Sensor level indication	Two binary outputs, active low
Other outputs	
Power supply sensor	± 15 VDC / 100 mA
Voltage reference	+ 10 VDC /10 mA
Options / accessories	
Rotary and linear sensors	see page 42
Programming tool	see page 47
Programming tool and display	see page 47
Window software	see page 47
Terminal mode communication	see page 47
Memory card	see page 47

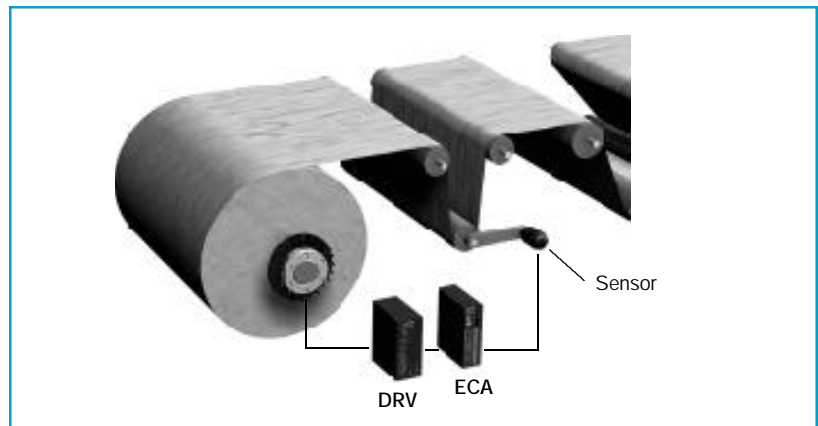



MCS2000-CTDA / CTLC

CONTROLS

MCS2000-CTDA and CTLC are packaged versions. Power supply, programming keyboard and display are built in. In the **CTLC** version (load cell), two load cell amplifiers are installed as standard.

For both **MCS2000-CTDA and CTLC** two software versions are available. See specifications below.



Common specifications

Input power supply 110-240 VAC selectable

Analogue inputs
Two analogue inputs 0-10 VDC

Analogue outputs
Two controlled channels ± 10 VDC, 0-20 mA
Open loop signal 0-10 VDC

Digital inputs
Set point change + active low
Set point change - active low
Set point change \pm front face switch
Gain multiplier active low
Output limitation active low
ABC binary combination active low
ABC inputs synchronisation active low
Stop integral form active low

Digital outputs
Sensor level indication Two binary outputs

Other outputs
Power supply sensor ± 15 VDC / 100 mA
 $+ 5$ VDC / 100 mA
Power supply 24 VDC
Voltage reference $+ 10$ VDC / 10 mA

Options /accessories
Memory card see page 47
Window soft see page 47
Rotary and linear sensor see page 42

Common features of all versions

- Three mounting possibilities.
- Software password protected.
- Fully digital, scrolling menu program.
- Multipurpose application.
- RS232 communication.
- Two output channels.
- Automatic sensor scaling.
- Programmable output configuration.
- Output sensor information.
- External set point change.
- Automatic or imposed PID correction.
- All features requested for tension control.
- Pluggable memory card.

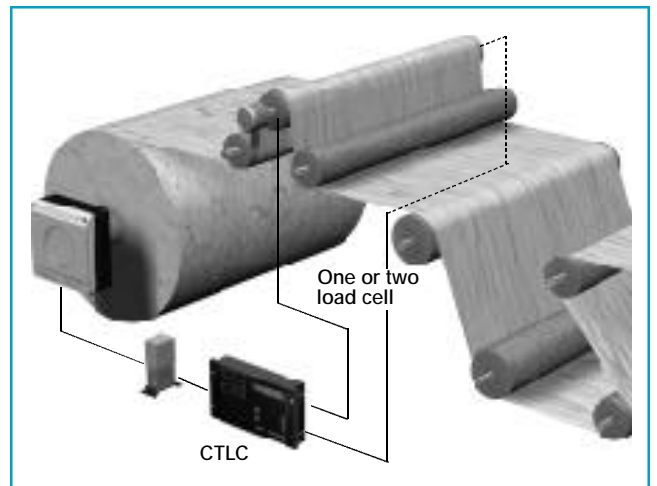



MCS2000-CTDA / CTLC

CONTROLS

Various models definitions – specifications – typical applications

Model	Characteristics	Applications
MCS2000-CTDA-10	RS232 One sensor input	Dancer feedback
MCS2000-CTDA-11	One sensor input Taper function Limited RS232	Dancer feedback
MCS2000-CTLC-10	RS232 Two scalable sensor input	Load cell feedback
MCS2000-CTLC-11	Two scalable sensor input Taper function Limited RS232	Load cell feedback

Taper function

The most usual application requiring taper function is the rewind stand where the initial tension on the core has to be automatically reduced as the diameter increases. Rewind diameter information / feedback is essential. The typical application is slitter where no intermediate driving roll is present. The unwind tension, in this case, is the same as rewind and has to be tapered. The tension is identical in zone X and Y.

The tension reference on the controller MCS2000-CTLC-11 is continuously corrected according the rewind diameter information coming from the driving system or from an ultrasonic sensor measuring the rewind diameter.

The taper function allows a perfect rewind roll shape (mainly avoiding telescopic effect).

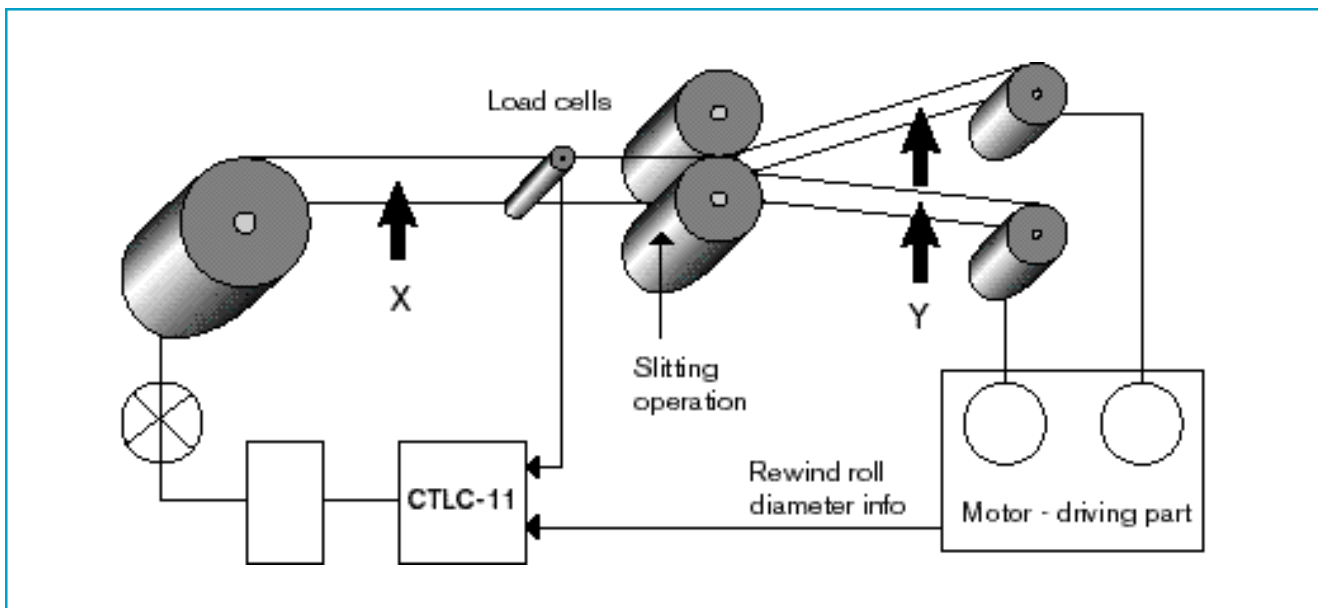



MCS2000 - Important features

CONTROLS

MCS2000 line is provided with very interesting and useful features. Below is a brief description of the most interesting ones.

As already stated, the main problem in tension control is the roll inertia change during operation. The PID function is optimal for one inertia value. The MCS2000 line is provided with an important feature which is the PID correction. Based on the available diameter information you can apply a continuous PID correction. When no information is available, an internal PID change can be programmed.

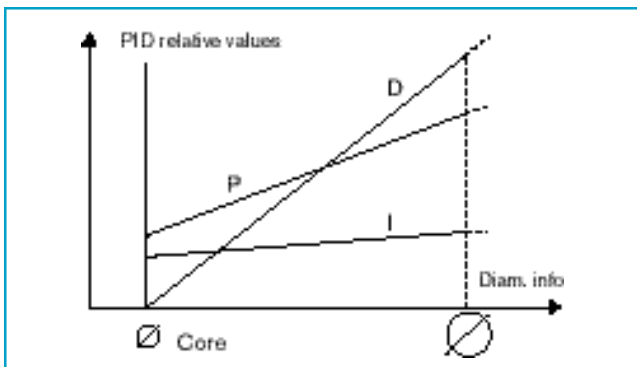

Each parameter P, I and D can be set individually for the smallest (core) and biggest diameter. As soon as the correct parameters are found for the extreme diameter value, they are stored. The diameter information provided will fix the PID values for the present diameter value. This will allow the system to keep an excellent stability during the whole diameter evolution. In the case where the diameter information is not available we can provide this signal by installing a sonic sensor or by working with internal correction. The external diameter information supplied to the controller will ensure a better precision compensation compared to an internal correction.

WHATEVER YOU NEED MCS2000 CAN REPLY ...

You need the tension control connected to PLC.	Use RS232 communication.
You need an adaptive PID due to big diameter ratio.	Use internal or external PID correction. Use RS232 communication to operate the correction.
You already have your own load cell.	MCS2000-CTLC can accept any signal.
You have flying splice on the machine.	MCS2000 can manage it.
You need to control a brake and a motor.	MCS2000 can control both.
You have a multi-material machine range.	Use memory card to load the correct programme. Use RS232 communication to change the parameters. Use Window software to load the correct programme.
You need taper function.	Use the right MCS2000 model including this function.
Your feedback is a 0-10 V.	MCS2000 can accept any signal range.
You need to work in open + closed loop.	MCS2000 is provided with both function.
You finally found a perfect setting.	Save it on a memory card as back-up.
You need to display the tension in Newton, kilo...	MCS2000 can be programmed for any unit.
You have a very special application.	We can assist you in control definition. Ask Warner representative, we can propose any customised solution / software.



Open loop control - MCS2000, CTOL-00

CONTROLS

MCS2000-CTOL-00 control is purely dedicated to the open loop control. There are two main uses: diameter calculator and ultrasonic sensor roll measurement. This control can be an alternative where the required tension precision is not critical.



Specifications

Input power supply 24 VDC \pm 5%, 0,2 Amp

Analogue inputs

- Line speed 0-10 VDC
- Rotation speed 0-10 VDC
- Ultrasonic sensor 0-10 VDC
- Torque offset 0-10 VDC
- Torque setting 0-10 VDC

Pulse input for rotation speed 1, 2, 4 pulse/rpm

Analogue outputs

- Sonic diameter info 0-10 VDC
- Diam. Calcul info 0-10 VDC
- Main output signal 0-10 VDC
- % main output signal 0-10 VDC

Digital inputs

- Calculator reset Active low
- Calculator freeze Active low
- Fast stop Active low
- Out OFF Active low
- Out ON Active low
- Out HOLD Active low

Digital output

- Diameter level out Relay, 24 VDC/0,2 Amp

Features

- Diameter calculator function.
- Ultrasonic sensor function.
- DV/dt compensation.
- Remote tension control.
- Automatic diameter value store.
- Master - % slave dual output.
- Initial reset calculator value.
- Dynamic friction compensation.
- Static friction compensation.
- Fast stop capability.
- Large 2 x 16 characters display.
- Taper function for rewind.

Standard application with diameter calculator

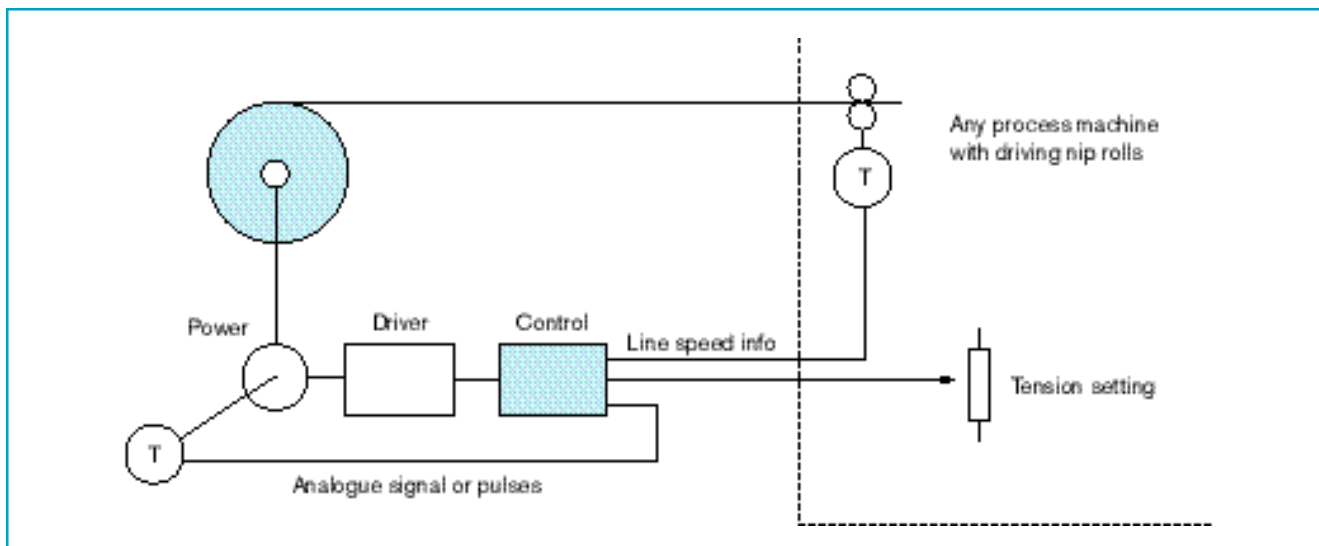



CONTROLS

MCS2000 control line - Dimensions

MCS2000-ECA
MCS2000-CTDA-10 / CTDA-11 / CTLC-10 / CTLC-11 / CTOL-00
(same physical dimensions)

Dimensions [mm]

MCS2000

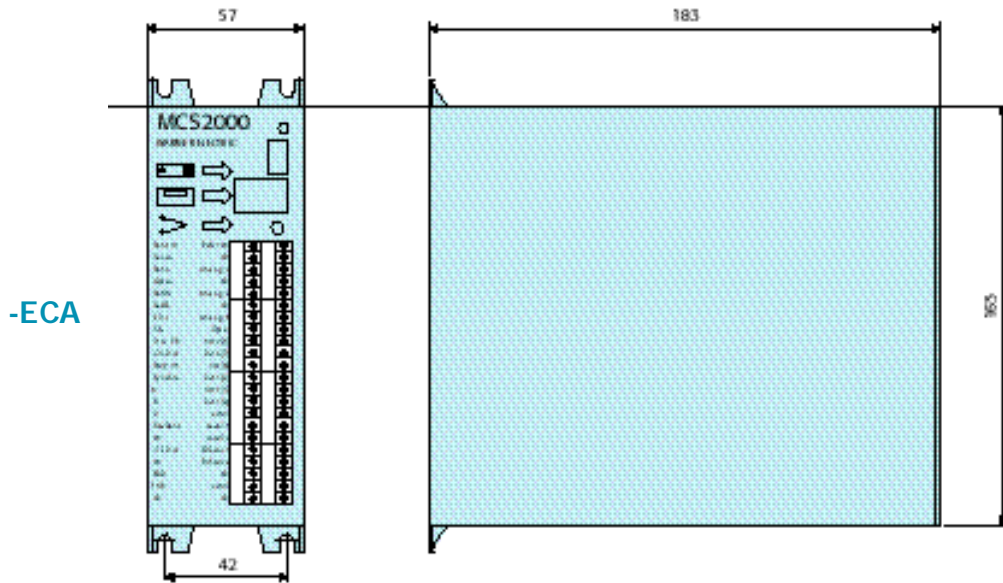

MCS2000-CTDA, MCS2000-CTLC, CTOL

MOUNTING

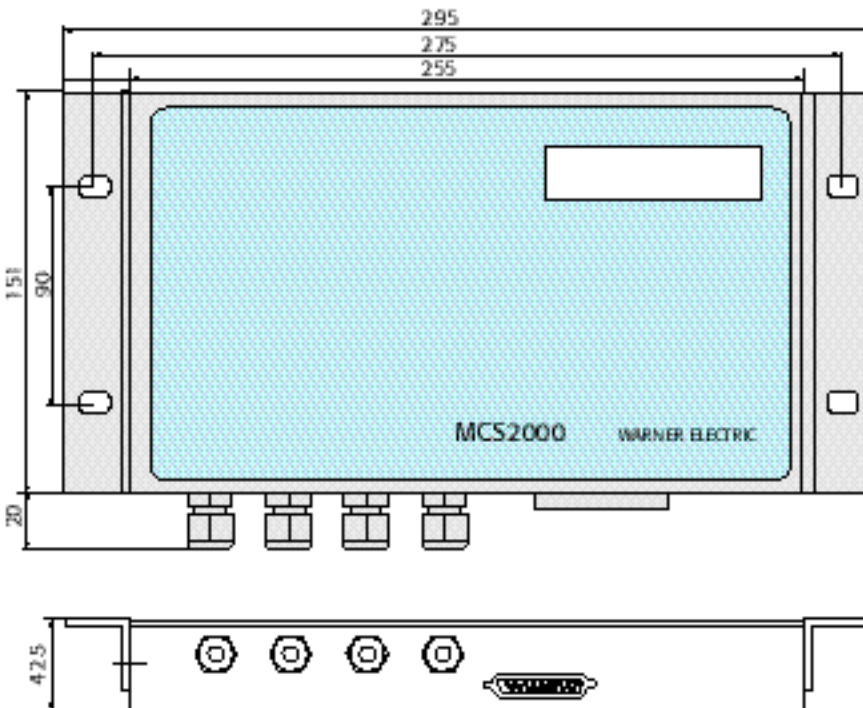

Front panel mounting



Wall mounting



DIN rail mounting

