

Notes

- For CSH brakes, the maximum clamping force is with new pads. i.e. no wear on friction pad. Minimum clamping force is with 1 mm wear per friction pad, i.e. before brake adjustment required. For CHS hydraulically engaged brake the clamping force is independent of pad wear.
- Loss of force is % for each 1 mm of total pad wear on CSH brakes. CHS brakes have no loss of force with wear.
- Braking force and torque for CSH are based on minimum clamping force with 0.4 nominal coefficient of friction and two braking surfaces. Braking force and torque for CHS brakes are based on 0.4 friction coefficient and two braking surfaces. Force is proportional to the hydraulic pressure applied. Max operating pressure 110 bar in CHS module.

Minimum reaction time = 0.05 sec
 Oil volume for each Actuator = 5 cm³/mm of piston stroke.
 Minimum stroke = 1 mm. i.e. total minimum air gap = 1 mm.
 Maximum stroke for CSH = 3 mm before

TABLE 1 - Performances						
Metana Caliper	Clamping force ⁽¹⁾		Loss of force ⁽²⁾	F _b tangential or braking force ⁽³⁾	Operating pressure	Weight
	min (N)	max (N)				
CSH Spring applied / Hydraulic release brake						
CSH 28-1/0/3.2	4000	4700	5	3200	20	66
CSH 28-1/1/5.2	6500	7500	6	5200	35	66
CSH 28-1/2/8	10000	11500	6	8000	45	66
CSH 28-1/3/10.4	13000	15000	6	10400	60	66
CSH 28-1/4/14	17500	20000	6	14000	80	66
CSH 28-1/5/15.2	19000	23000	7	15200	100	66
CSH 28-1/6/17.6	22000	30000	13	17600	130	66
CSH 28-2/4/28	35000	40000	6	28000	80	90
CSH 28-2/5/30.4	38000	46000	7	30400	100	90
CSH 28-2/6/35.2	44000	60000	13	35200	130	90
CHS Hydraulic applied / Spring released brake						
CHS 28-1	-	30000	0	24000	110	65
CHS 28-2	-	60000	0	48000	110	89

adjustment required.
 Maximum stroke for CSH = 10 mm
 Special mounting:- The CSH or CHS hydraulic module i.e. the part containing the piston may be used separately on customer's own bracket. The bracket thickness between two opposing modules should be 51 mm wider than the brake disc thickness. This allows for total air gap of 1mm when new.
 Please consult Wichita for further details

TABLE 2 - CSH28 BRAKE TORQUE BY DISC DIAMETER (Nm)										
Disc diameter (mm)	CSH28-1/0/3.2	CSH28-1/1/5.2	CSH28-1/2/8	CSH28-1/3/10.4	CSH28-1/4/14	CSH28-1/5/15.2	CSH28-1/6/17.6	CSH28-2/4/28	CSH28-2/5/30.4	CSH28-2/6/35.2
600	752	1222	1880	2444	3290	3572	4136	6580	7144	8272
800	1072	1742	2680	3484	4690	5092	5896	9380	10184	11792
1000	1392	2262	3480	4524	6090	6612	7656	12180	13224	15312
1200	1712	2782	4280	5564	7490	8132	9416	14980	16264	18832
1500	2192	3562	5480	7124	9590	10412	12056	19180	20824	24112
2000	2992	4862	7480	9724	13090	14212	16456	26180	28424	32912
2500	3792	6162	9480	12324	16590	18012	20856	33180	36024	41712
3000	4592	7462	11480	14924	20090	21812	25256	40180	43624	50512
3500	5392	8762	13480	17524	23590	25612	29656	47180	51224	59312
4000	6192	10062	15480	20124	27090	29412	34056	54180	58824	68112

Wichita Metana model codes	
CSH	Caliper Spring applied Hydraulic release
CSH 28	is a code for this frame size
CSH 28-1	has 1 actuator
CSH 28-2	has 2 actuators
CSH 28-1/0 or /1, /2, /3, /4, /5, /6	is a code for spring strength
CSH 28-1/1/5.2	is the tangential force (kNm)

Dimensions

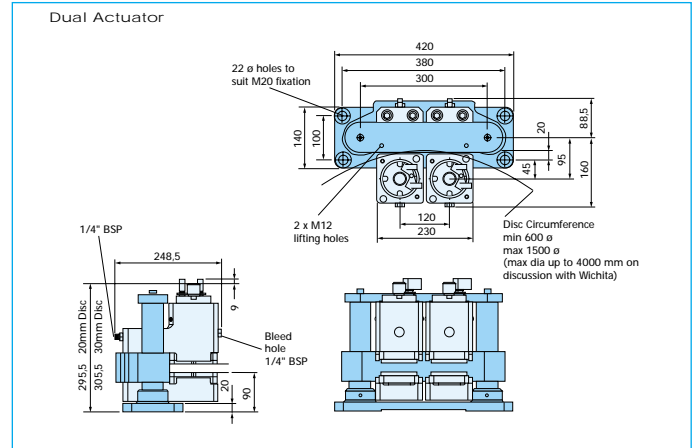
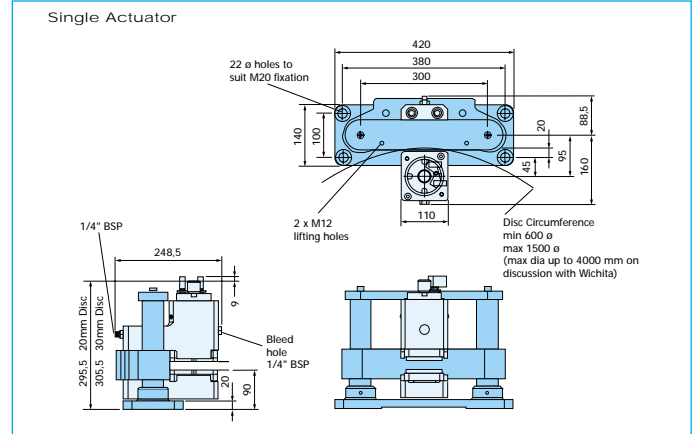



Metana Caliper Brake

DESCRIPTION

The Wichita Metana Caliper brake is available in either Spring applied / Hydraulic release or Hydraulically applied / Spring release options. It is available in a single frame size although special mounting to suit customers requirements may be possible. The brake is designed for medium to heavy duty applications where high energy stopping and holding duties are required.

GENERAL FEATURES AND ADVANTAGES

- Wide torque capacity.
- Single or Twin Actuators within one frame size.
- Compact and Robust design.
- High heat capacity.
- Friction linings available in both Organic and Sintered materials to suit any conditions.
- Self aligning friction pads.
- Self centering.
- Single Face, four point mounting to established standards.
- Ease of installation.
- Ease of service.
- Optional friction lining wear indication.
- Mechanical release available in case of hydraulic failure.

- Easy access to hydraulic oil connections on body of actuators.
 - Hydraulic oil connections are away from area of brake disc – less chance of oil contamination.
- ### OPTIONS
- Brake discs 600 mm (min) to 4000 mm (max) diameter can be used.
 - Brake discs can be supplied by Wichita.
 - Brake disc thickness – 20 to 30 mm.
 - Friction lining wear indication from micro switch signals.
 - Brake "ON" indication from micro switch signals.
 - Special corrosion protection for severe operational conditions.

MOUNTING

- Industry established - 4 x M20 Bolts on 380mm X 100mm centres.
- Base plate 420 mm x 140 mm x 20 mm.
- Overall height 275 mm + disc width (This excludes Eye bolt and limit switch fittings).
- If more than one caliper is used on a disc they should be equi - spaced around the circumference of the disc i.e. Two calipers should be at 180 degrees to each other, three at 120 degrees and so on.

See Installation and Maintenance Instructions (EDS 1.12.18) for detailed information regarding mounting and other general advice.

GENERAL INFORMATION

The brake is designed to operate with mineral based hydraulic oil that complies with AWS Specification 32. A 10 Micron filter should be used in the system.

Normal operation is at a maximum hydraulic oil pressure of 140 bars.

The torque generated by each CSH caliper assembly is dependant on the number and rating of the springs fitted in the actuator. The torque generated by each CHS caliper assembly is proportional to the pressure applied. The brake code description precisely identifies each assembly, (see table 1).

We will be pleased to provide advice and supply suitable brake discs to suit virtually any application. Let us know the application data and all other requirements.

Maximum engagement speed – sintered friction pads = 100 m/sec.
Maximum engagement speed – organic friction pads = 30 m/sec.

Friction pad coefficient of friction – 0.4

BRAKE TORQUE AVAILABLE

Table 1 details the performance of the various spring and actuator combinations that are available. Using the information in this table the braking torque can be calculated for any diameter disc.
Use the formula :
Brake torque per caliper assembly = $F_b \times (R - 0.065)$ Nm

Where F_b = Braking Force (N)
 R = Radius of brake disc (m)
Centre of friction pad to disc edge = 0.065 m

This formula gives a value for the torque available for a particular disc diameter with one caliper assembly, (consisting of one or two actuators). Multiply this torque figure by the number of additional identical caliper assemblies to be applied to the disc to obtain the total torque available.

* Service conditions can vary, so as a guide to ensure performance is always maintained use a service factor of 75% of the calculated torque figure when making a selection against a working / design value.

Table 2 provides a quick reference of the torque available from the different models and spring combinations with a range of standard brake disc diameters. All torques given are with a single caliper assembly on the disc. The caliper assembly may consist of one or two actuators dependant on the torque rating required.

* Service conditions can vary, so as a guide to ensure performance is always maintained apply a service factor of 75% on the tabulated torque figures when making a selection against a working /design value.

Single actuator assembly showing mounting bolts and screws.



Close up of limit switches for monitoring brake pad wear state and actuator position (On or Off)



TYPICAL APPLICATIONS

- Wind Turbines – Rotor Stopping and Yaw Control
- Mine Winder Main Drum Braking
- Lift/Elevator holding duties
- Heavy duty winches
- Motor holding brakes
- Marine – Propeller shaft holding duties

