











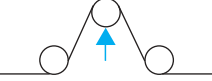

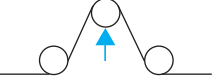

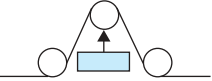

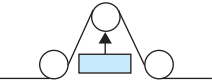

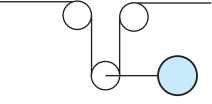

SENSOR ACCESSORIES

Sensors overview

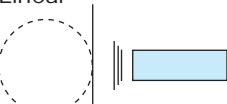
Working in closed loop requires a web tension **SENSOR**. When working with load cell the system is called "Direct Tension Feedback". When working with dancer arm the system is called "Indirect Tension Sensor". Position sensors are divided in two categories: linear and rotary.

SENSOR OVERVIEW

MODEL	TYPE / SYMBOL	RANGE	MAIN CHARACTERISTICS	
ES01	End shaft load cell 	<input type="checkbox"/> 50 N to 2000 N <input type="checkbox"/> 6 tension ranges <input type="checkbox"/> Resistive bridge	<input type="checkbox"/> Typical output voltage: 20 mV at full load <input type="checkbox"/> 40 mm ball bearing diam.	
ES02	End shaft load cell 	<input type="checkbox"/> 250 N to 2000 N <input type="checkbox"/> 4 tension ranges <input type="checkbox"/> Resistive bridge	<input type="checkbox"/> Typical output voltage: 20 mV at full load <input type="checkbox"/> 52 mm ball bearing diam.	
FM01	Foot mounted load cell 	<input type="checkbox"/> 100 to 5000 N <input type="checkbox"/> 6 tension ranges <input type="checkbox"/> Resistive bridge	<input type="checkbox"/> Typical output voltage: 5 VDC at full load <input type="checkbox"/> Incorporated amplifier	
FM02	Foot mounted load cell 	<input type="checkbox"/> 5000 N to 10000 N <input type="checkbox"/> 2 tension ranges <input type="checkbox"/> Resistive bridge	<input type="checkbox"/> Typical output voltage: 5 VDC at full load <input type="checkbox"/> Incorporated amplifier	
MCS605-E	Rotary 	<input type="checkbox"/> $\pm 100^\circ$ <input type="checkbox"/> Resistive conception	<input type="checkbox"/> Typical output voltage: ± 3.75 VDC for ± 15 VDC power supply and $\pm 30^\circ$	
MCS705-E	Rotary 	<input type="checkbox"/> $\pm 100^\circ$ <input type="checkbox"/> Optical conception	<input type="checkbox"/> Typical output voltage: ± 3.75 VDC for ± 15 VDC power supply and $\pm 30^\circ$	
SCUA-030	Linear 	<input type="checkbox"/> 0 to 1 m <input type="checkbox"/> Ultrasonic measure	<input type="checkbox"/> Typical output voltage: 0-10 VDC for 0-1m	
SCUA-040	Linear 	<input type="checkbox"/> 0 to 3 m <input type="checkbox"/> Two distance ranges <input type="checkbox"/> Ultrasonic measure	<input type="checkbox"/> Typical output: 0-10 VDC for nominal distance	
MCS905-E	Linear 	<input type="checkbox"/> 50 mm stroke <input type="checkbox"/> Resistive conception	<input type="checkbox"/> 5-30 VDC power supply Self-aligning bearing 2k resistor	

DO NOT FORGET: The sensor is the most important element when working in closed loop and has to be accurate, with good repeatability.

- Place load cell in order to measure web tension, minimise the dead load and all other stress interferences on it.
- When using dancer solution create the desired tension with true force (pneumatic cylinder) and not with weight.
- When measuring distance avoid hysteresis in the movement. In general, sensor must be the exact image of the value we have to measure.



**SENSOR
ACCESSORIES**

End shaft load cell type ES

END SHAFT LOAD CELLS are normally used in new machines designed with the possibility to place the load cell directly on the sensing roll. The end shaft version offers the advantage of being able to easily place the load cell in any tension resultant direction. The **ES** model exists in two versions differentiated by the diameter of ball bearing which has to be placed inside.

END SHAFT TYPE ES01-...and ES02-...

All end shaft load cells are based on the Wheatstone bridge principle. They have no built-in amplifier. They are delivering a signal which is proportional to the voltage supply and tension applied. It is important to respect the measurement direction referenced on the load cell body (normally an arrow indicates the sensitive direction).

ES... LOAD CELL FEATURES



	ES01-40C and ES02-52C
Power supply	10 to 15 VDC / 40 mA (± 5 VDC in Wichita control)
Sensitivity	2 mV / V supply at nominal load 1 mV / V supply for 50 and 150 N models
Rating	50-150-250-500-1000-2000 Newton
Connections	5 m shielded cable supplied
Mechanical overload	Max 150 % in any direction
Dimensions	See mounting instructions ref. MC481 and MC482
Mounting	See recommendations on page 11

ELECTRICAL CONNECTIONS ES01-... and ES02-...

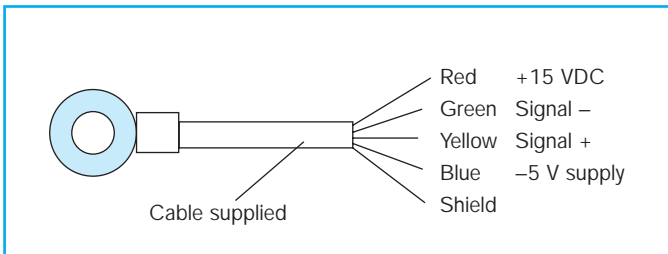

IMPORTANT:

ES01-40C requires a ball bearing with external diameter 40 mm

ES02-52C requires a ball bearing with external diameter 52 mm

Ball bearing must be self-aligning type to allow web tension measurement only (no other external constraints).

AVAILABLE MODELS / CAPACITY

Nominal	50 N	150 N	250 N	500 N	1000 N	2000 N
ES01-...	-50-40C	-150-40C	-250-40C	-500-40C	-1000-40C	-2000-40C
ES02-...	-	-	-250-52C	-500-52C	-1000-52C	-2000-52C

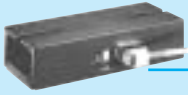

SENSOR ACCESSORIES

Sensors / Accessories

The foot mounted load cell is the ideal solution for machine retrofitting or for heavy tension measurement. The foot mounted model has to be installed with a pillow block type ball bearing supporting the sensing shaft.

FM01-.... and **FM02-....** are only differentiated by the physical dimensions.

FOOT MOUNTED TYPE FM01-.... and FM02-....

Foot mounted load cells are available in two versions:

With incorporated amplifier. **FM..-....AC**

Without amplifier. **FM..-....C**

AC = amplifier and connector on the load cell body.

C = connector on load cell body.

Specifications (all FM SERIES)



	FM.....-AC	FM.....-C
Power supply	±12 to ±15VDC	± 5 VDC or +10 VDC
Sensitivity	0.5 VDC, nominal load	10 mV, nominal load
Rating	100 – 250 – 500 – 1000 – 2500 – 5000 – 10000 Newton	
Connections	Cable supplied, see below	
Permitted overload		
– Compression	150 %	
– Extension	120 %	
Radial permitted force	50%	
Dimensions	See mounting instructions ref. MC480	
Mounting	See recommendations on page 11	

ELECTRICAL CONNECTIONS FM....-AC

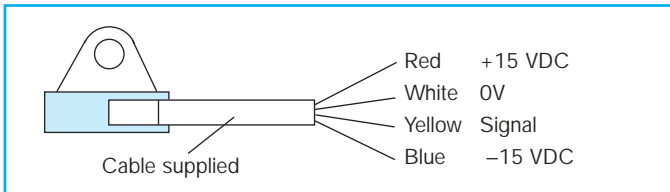

ELECTRICAL CONNECTIONS FM....C

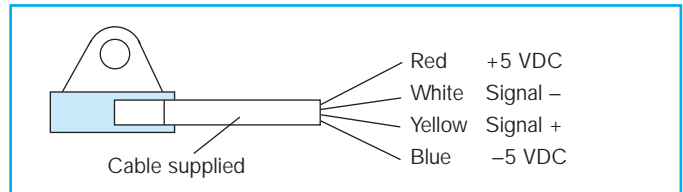

SETTING (FOR FM....AC only)

Load cell is factory scaled for:

- No load – 0V output.
- Nominal load – 5V output.

The load cell does not need to be rescaled for normal use in closed loop. However, a rescaling after installation is possible by using potentiometer and LED indicators.

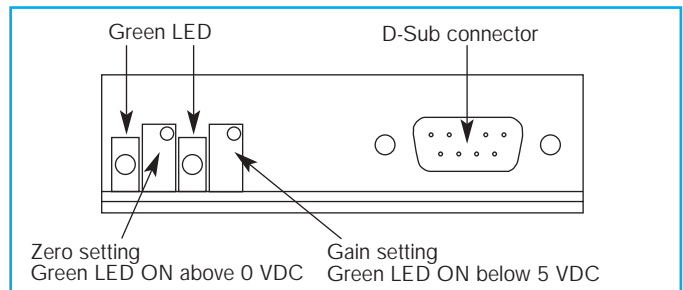

AVAILABLE MODELS / CAPACITY

Nominal	100 N	250 N	500 N	1000 N	2500 N	5000 N	10000 N
FM01..-	-100-AC	-250-AC	-500-AC	-1000-AC	-2500-AC	-5000-AC	
FM01..-	-100-C	-250-C	-500-C	-1000-C	-2500-C	-5000-C	
FM02..-						-5000-AC	-10000-AC
FM02..-						-5000-C	-10000-C



SENSOR ACCESSORIES

Rotary sensors

POSITION SENSOR

A position sensor is used in two possible ways:

- ☐ To detect dancer moving in the closed loop installation working on dancer principle.
- ☐ To sense the diameter of the roll to operate open loop control or make PID compensation in closed loop installation.

ROTARY SENSOR



	MCS605-E	MCS705-E
Power supply	10 to 30 VDC / 30 mA (or ± 5 to 15 VDC)	10 to 30 VDC / 30 mA (or ± 5 to 15 VDC)
Max detection angle	200° or $\pm 100^\circ$	200° or $\pm 100^\circ$
Sensitivity	2,5 mV / V / °	
Option:		
Mounting kit	See page 48	See page 48

ELECTRICAL CONNECTIONS

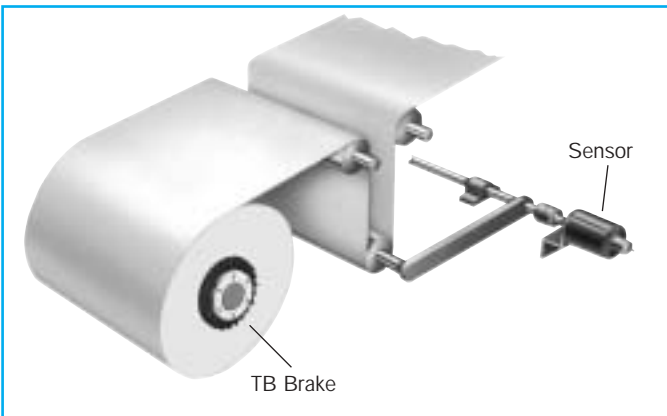
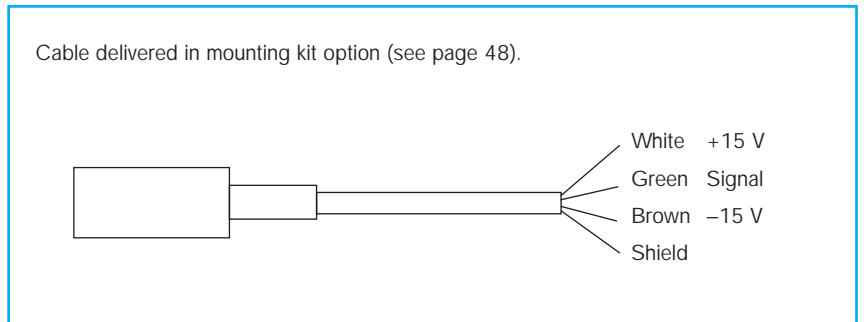
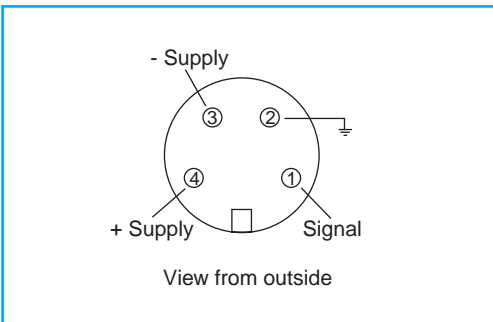

Working in closed loop with the arm dancer principle is very popular, especially in the printing market where a good flexibility of the system is required to absorb the eventual "tension peaks". The rotary sensor is necessary to read the dancing roll movement.

MCS605-E and MCS705-E are ideal for easy mounting. They are encapsulated in rugged metal housing, preventing mechanical shocks. Furthermore they are provided with built-in switch in order to change the signal output polarity.

Optional mounting kits facilitating quick and easy fitting on the machine are available. Each kit is composed with brackets, cable, coupling and screws (see page 48).



SENSOR ACCESSORIES

Ultrasonic sensors & linear sensors

In the tension control market ultrasonic sensors have two primary uses:

- For roll diameter reading when the system operates in open loop.
- For loop position reading when the system operates in closed loop with dancer arm principle.

ULTRASONIC SENSORS TYPE SCUA....



	SCUA-030	SCUA-040/080
Power supply	18 to 30 VDC/45 mA	18 to 30 VDC/70 mA
Analogue output	0-10 VDC/ 0 – 1m	0-10 VDC/0-2-3 m.
Digital output	Adj. from 0,15 to 1 m	Adj. from 0,2 to 2,3 m.
Min measure distance	0,15 m	0,2 m
Max measure distance	1 m	2m / 3 m
Housing	Cylindric M18	"Cube"
Accessory	1, 5 m cable delivered	Mounting bracket 3 m cable attached
Option	6 m cable reference : SCUA-032	
Dimensions	See mounting instructions ref. MC485	See mounting instructions ref. MC486

ELECTRICAL CONNECTIONS

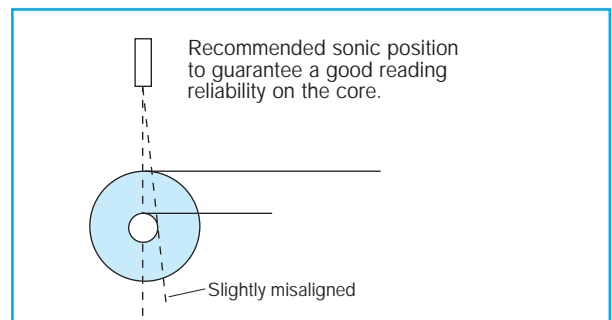
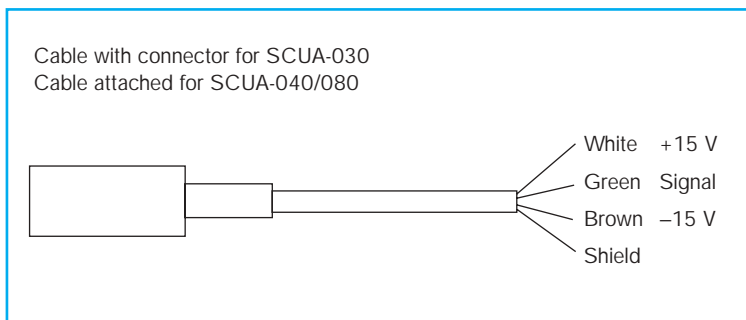

LINEAR RESISTIVE POTENTIOMETER



	MCS905-E
Power supply	5 to 30 VDC
Resistor value	2 K
Electrical stroke	50 mm
Fixation	2 self-aligning bearing
Cable	0,5 m attached
- Red and black	Voltage supply, not polarised
- Yellow	Wipper (output signal)

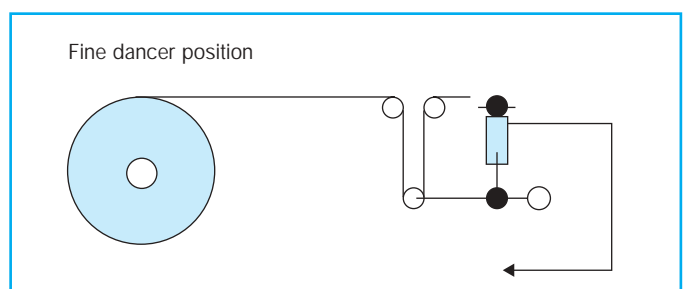









**SENSOR
ACCESSORIES**

MCS2000 line – Accessories

*All material not entering in the main open or closed loop function is listed in the **ACCESSORY** chapter. This concerns mainly power supply, cable, programming tool, display, amplifier*

MCS2000 LINE – ACCESSORIES

	DESIGNATION	MAIN CHARACTERISTICS
 MCS2000-PRG	Hand programmer for MCS2000-ECA.	2 x 16 characters display. Powered from MCS2000-ECA. Connectable and disconnectable during operation. Cable supplied.
 MCS2000-CRD	Memory card for MCS2000-line.	Compatible ECA, CTDA, CTLC. 2 full programmes capacity. Easy load and downloading to control unit. Automatic downloading to control unit. Dimensions: 40 mm x 15 mm.
 MCS2000-IS	Load cells amplifier and Sonic sensor interface. Use as load cells amplifier and adder when two load cells are connected. Can accept any load cell signal between 20 mV and 10 V. Usable as sonic interface for low cost open loop tension control.	Power supply: 24 VDC \pm 10%, 300 mA Input load cells: 2 inputs – from 2m mV to 10 V / 5 K Input sonic: 1 input – delta voltage min 2 V Other inputs: 0-10 VDC / 10 K Signal output: 2 outputs – 0-10 VDC Power output: \pm 5 or 15 VDC to power load cells +24 VDC to power sonic.
 MCS2000-DP	Panel mounted programmer + display for MCS2000-ECA. (same characteristics as MCS2000-PRG but designed for panel mounting)	2 x 16 characters lines display. Powered from the MCS2000-ECA.
 MCS200-PS	24 VDC power supply unit.	Power supply: 100–250 VAC autoranging Output: 24 VDC \pm 5%, 3,1 Amps
MCS2000-PLC	List of codes available on request.	RS232 communication for MCS2000 line.
 MCS2000-WIN	3 diskettes or E-mail transmittable.	Compatible Windows 95–98. To programme MCS2000 control line.



**SENSOR
ACCESSORIES**

Rotary sensors – Accessories

MCS2000 product line supports RS232 communication. Every unit of the line can be connected to a PLC in terminal mode or / and programmed with PC. Using terminal mode requires various codes to transmit to the unit. Using the PC to programme the unit requires installation of Wichita software (Windows compatible). Both options are available.

MCS605-E – ACCESSORIES

The MCS202-Exx is designed to work with dancer arm principle. Usually the sensor is a rotary type.

Wichita sensor MCS605-E and MCS705-E can be delivered with complete mounting kit.

Mounting kit comprises of **CABLE**, **COUPLING**, **BRACKETS** and all necessary **SCREWS**. Various **KITS** are differentiated with various lengths of cable and cable with or without connector at control end side.

MCS2000 line requires free leads (MCS2000 control line is provided with terminal block).

MCS202-E1 requires a connector.

	Cable length	One / Two connectors	Compatible
MCS-KIT1	3 m	2	MCS202-Exx
MCS-KIT2	3 m	1	MCS2000
MCS-KIT3	4,5 m	2	MCS202-Exx
MCS-KIT4	4,5 m	1	MCS2000
MCS-KIT7	6 m	2	MCS202-Exx
MCS-KIT8	8 m	1	MCS2000

DIMENSIONS – MOUNTING

